

**Turn Off ALL Power and Breakers BEFORE Starting Install**

**Dometic Penguin wo/relay**

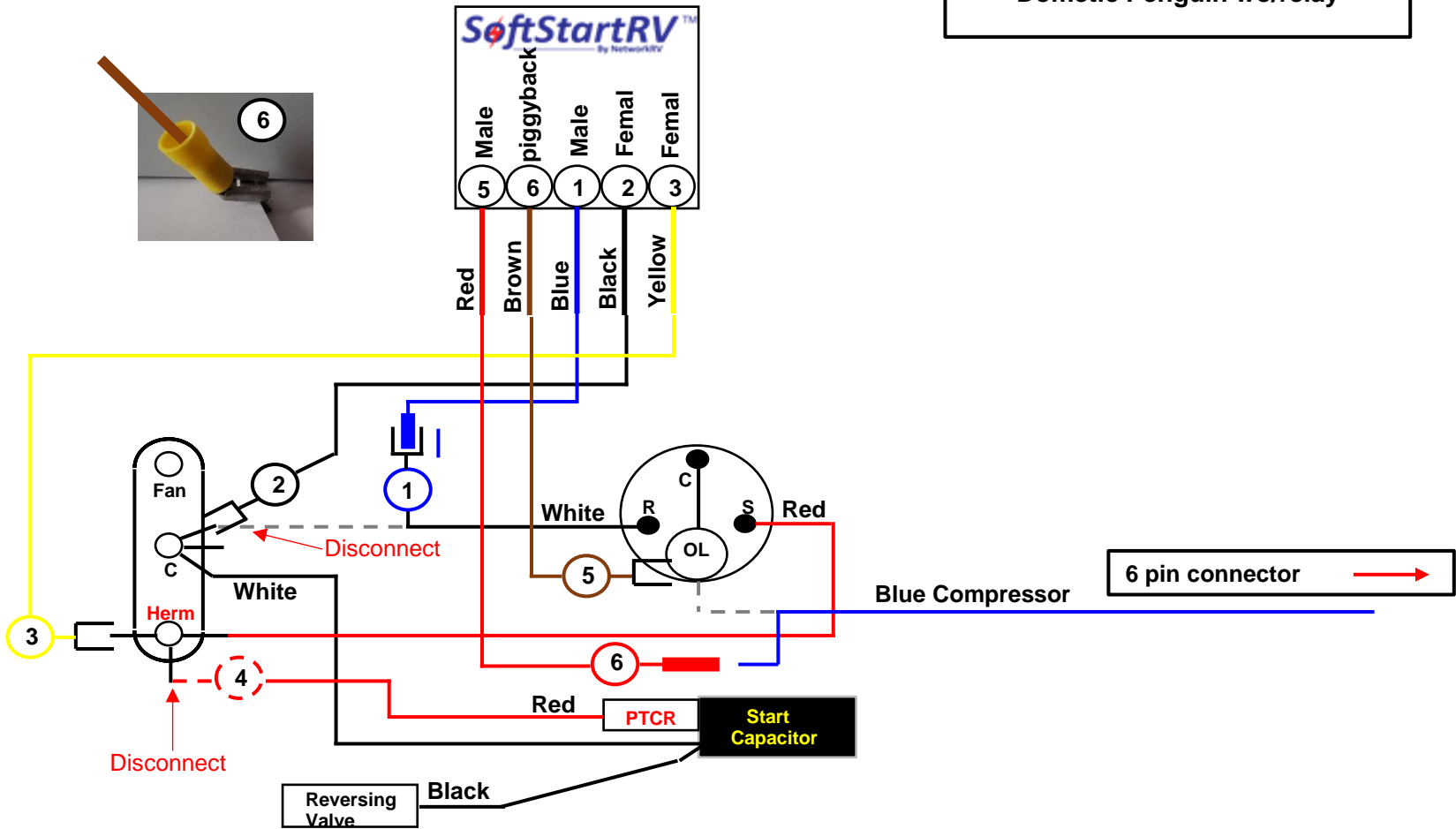

- Route Blue, Black and Yellow Softstart wire into your ele box,, Route Brown and Red Softstart wires to top of compressor.
- Crimp male disconnects and Blue and Red softstart wires, Crimp Female disconnects on Black and Yellow Softstart wires
- Crimp Piggyback (Male/female disconnect on red softstart wire, Then break male spade off.
- Step 1) Follow White compressor wire FROM compressor to "C" terminal of RUN Capacitor, Disconnect and connect to Blue Softstart wire.
- Step 2) Connect Black Softstart wire on terminal White compressor wire was on.
- Step 3) Connect Yellow Softstart wire on a terminal next to Red compressor wire on a "HERM" terminal.
- Step 4) **IF** you see a **2nd** red wire next to Red compressor wire Disconnect and Tape end and drop wire.
- Step 5) Remove compressor cap, Disconnect Blue compressor wire from overload and connect to Red Softstart wire, Tape connection.
- Step 6) Connect Brown Softstart wire on overload where Blue was, connect with curls of female in direction of jumper wire, then bend as shown fig 6

**Secure wires**

Turn Power and AC breaker on, Turn fan on Hi 1 min, Turn to Auto cool set Tstat to 55 and go look at run led light should be green  
 If no green light wait a full 3 min as Softstart may be in self test mode, If after 4 min no green light shut down and call tech support.  
 GREEN light on shut ac down replace all covers and turn AC back on set Tstat to near outside tempo and allow to run 30 min.  
 After 30 min you can operate as normal.