

Turn Off ALL Power and Breakers BEFORE Starting Install

Dometic Penguin High Efficiency Heat Pump or Straight AC wo/ Relay

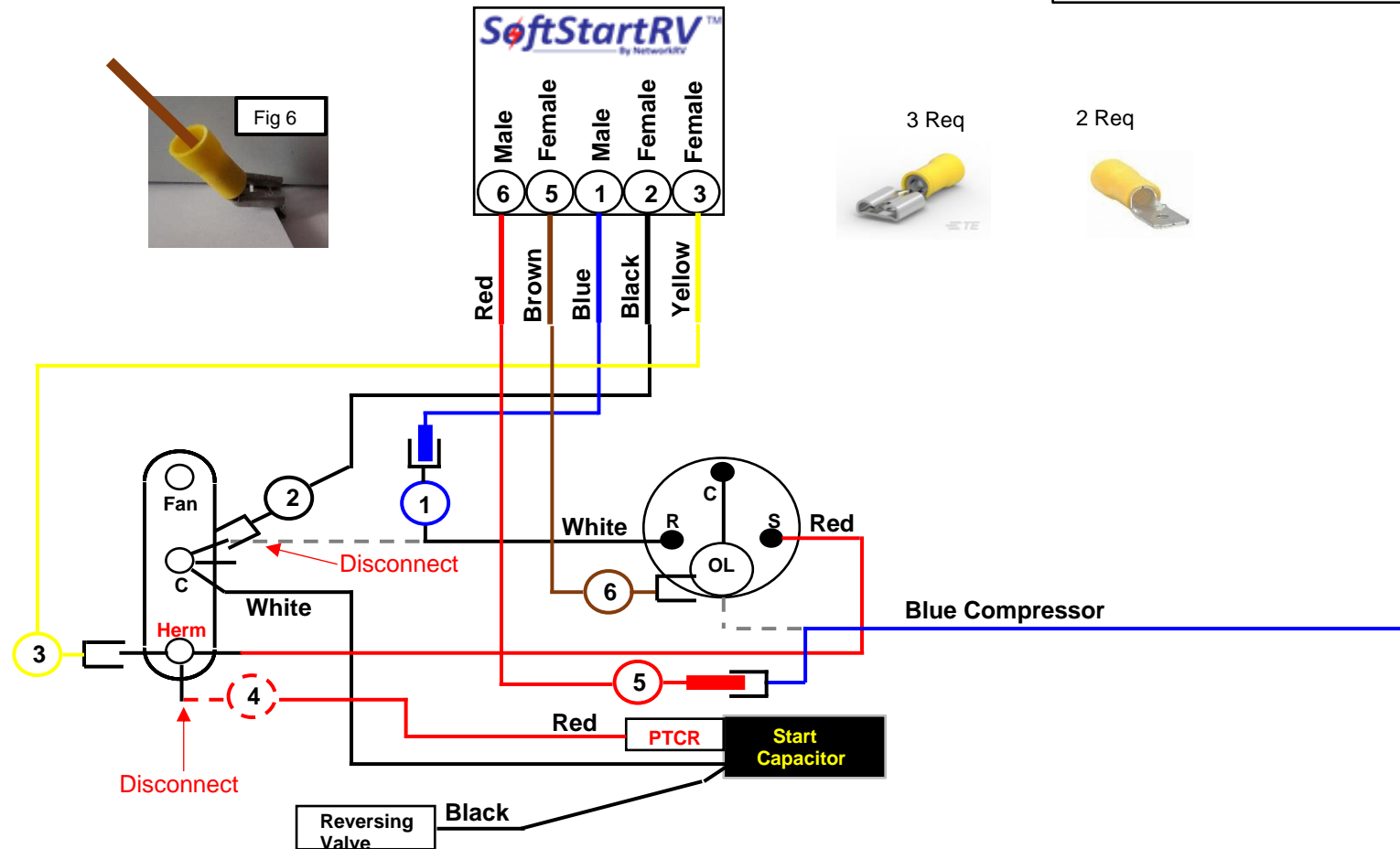

Route Blue, Black and Yellow Softstart wire into Ele Box, Route Brown and Red Softstart wires to top of compressor
Crimp disconnects on wire as shown in Softstart box above

IF you have 2 capacitors (1 plastic looking capacitor you MUST follow step 4 if NOT skip step.

Step 1) Follow White Compressor wire to the "C" terminal of the RUN Capacitor, Disconnect and connect to the Blue Softstart wire. Tape connection

Step 2) Connect Black Softstart wire on terminal White compressor wire was on.

Step 3) Connect Yellow Softstart wire on a terminal next to the Red Compressor wire on the "Herm" Terminals.

Step 4) **IF** you see a black capacitor and have a 2nd red wire next to the Red compressor wire **DISCONNECT** tape end and drop wire.

Step 5) Remove the Compressor cap, Disconnect the Blue compressor wire from overload and connect to Red Softstart wire. Tape connection

Step 6) Crimp Female disconnect on Brown Softstart wire and Bend as shown in fig 6 above, connect on overload terminal with bend toward white wire
You can move overload around to allow cap to fit back on, Replace and secure compressor cap

Secure All wires

Turn Power and AC breaker on, Turn fan on Hi 1 min, Turn AC to Auto Cool and set Tstat to 55, Go look at face of Softstart RUN Led should be green
If not green wait a full 3 min as unit may be in auto test mode, If after 4 min no green light contact Tech Support.

Once you see the Green light shut AC down replace all covers then turn AC back on set Tstat near ambient temp and allow to run 30 min.