

Turn All Power OFF BEFORE Starting Install

Advent Air Schematic and Installation Instructions

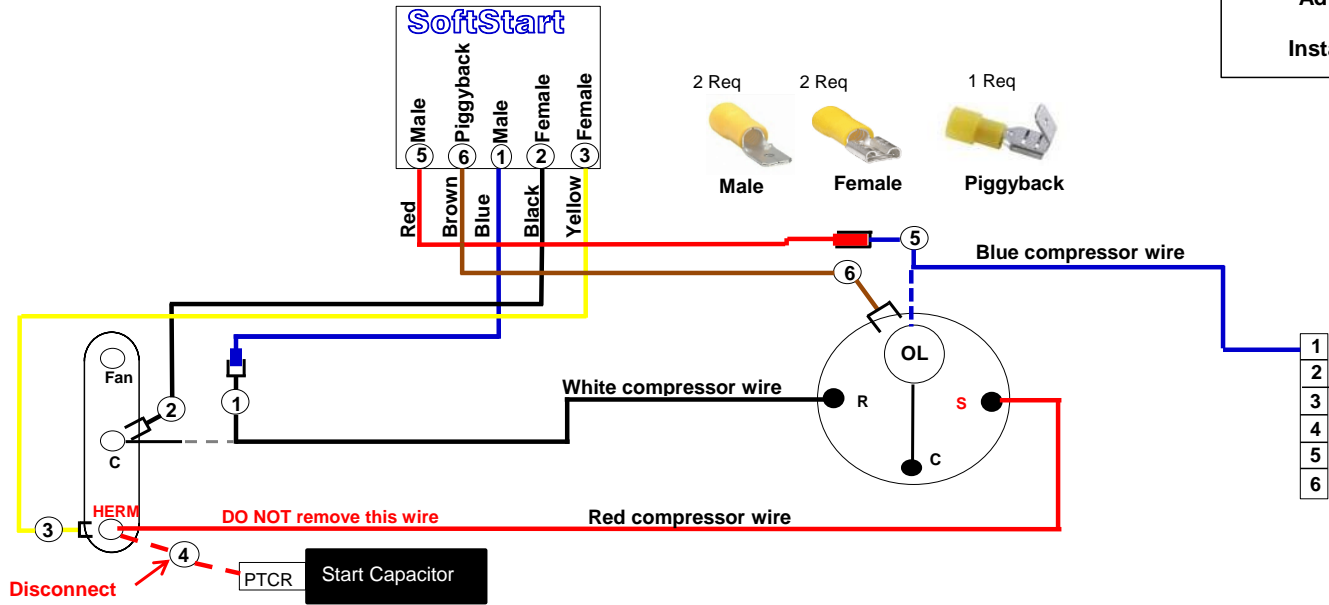

Begin by routing Blue, Black and Yellow Softstart wires into the electrical box. Then Crimp Disconnects on all softstart wire as indicated in Sofstart Drawing

Step 1) Follow White compressor wire from compressor to RUN capacitor "C" terminal, Disconnect and connect it to Blue Softstart wire.

Step 2) Connect Black Softstart wire to terminal White wire was on.

Step 3) Connect Yellow Softstart wire on a terminal next to Red compressor wire on "Herm" Side of RUN Capacitor.

Step 4) **IF** you see a **2nd red wire** next to red compressor wire disconnect and tape end . Drop it!

Step 5) Remove compressor cap, Disconnect Blue compressor wire and connect to Red Softstart wire, Tape connection, **NOTE:** wires do not go back under the cap.

Step 6) Crimp piggyback on brown Softstart wire, then break male part off, Connect brown Softstart wire on terminal blue wire was on with curls pointed toward red and white wires then bend connector as shown to the right, route brown wire over to red and white wires then replace cap



**Secure All wires and tape connections,** Turn Power and AC breaker on, Turn Fan on Hi 1 min, Turn AC to Auto cool set Tstat to 55

Look at Softstart led Green light should be on ( Green light compressor is running), If green light on shut down replace all covers, Turn AC back on and run 30 min

IF no green light enter Softstart Support Ticket for assistance