

**Turn Power and ALL breakers OFF Before Starting Install**

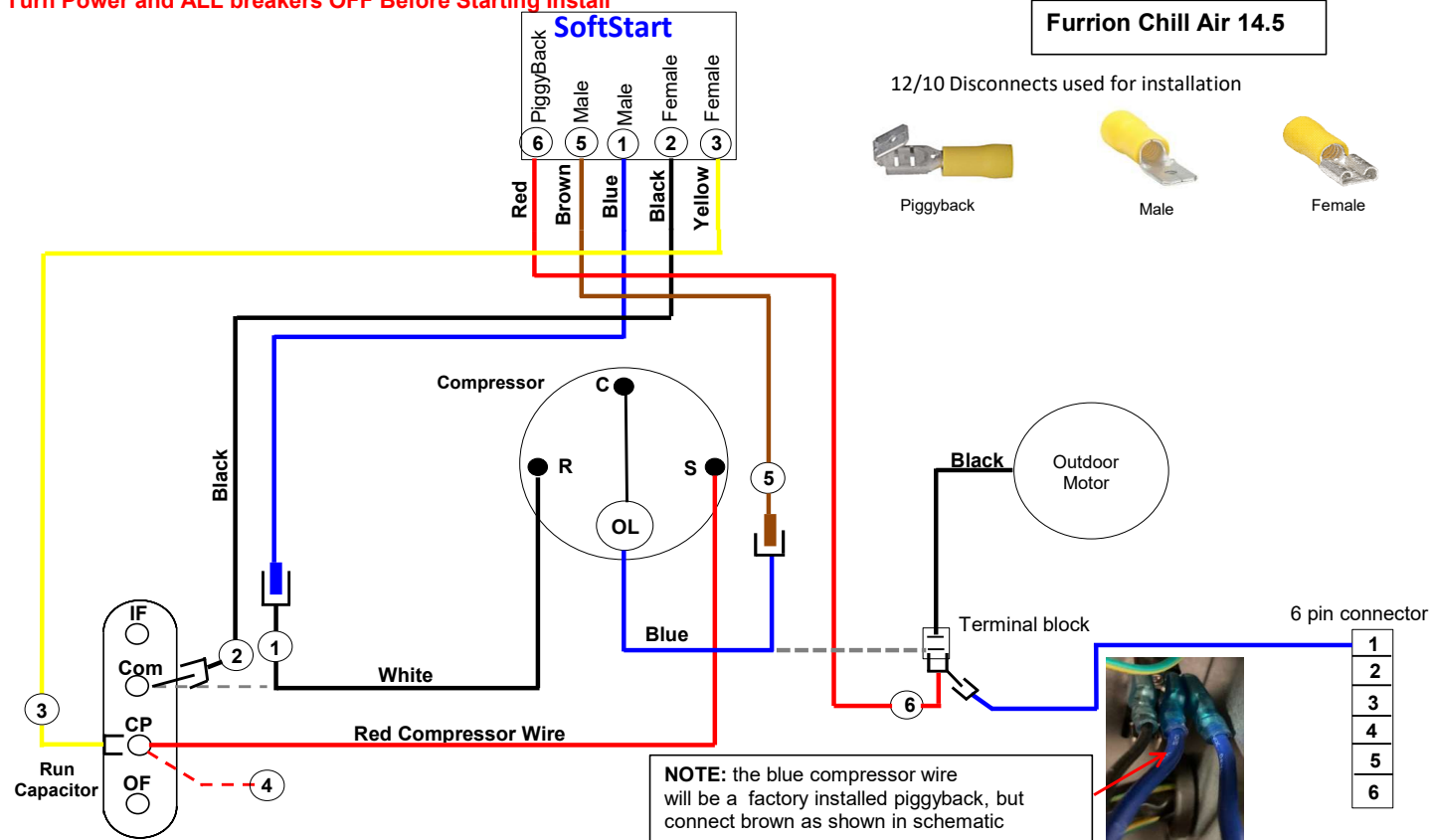

- Step 1) Follow White Compressor wire to Run Capacitor and Disconnect it, Connect Blue Softstart wire to White wire
- Step 2) Connect Black Softstart wire to Terminal White wire was on
- Step 3) Connect Yellow Softstart wire to a terminal Next to Red Compressor wire
- Step 4) **IF** You see a 2nd red wire next to the Red compressor wire DISCONNECT and tape it
- Step 5) Follow Blue compressor wire to the terminal block, Disconnect and connect wire attached to compressor to Brown Softstart wire
- Step 6) Crimp a Piggyback disconnect on the end of Red softstart wire and connect to terminal block, terminal on red softstart wire.

Connect blue compressor wire from 6 pin connector to Piggyback

**Secure All wires, Turn Power and AC breaker on, then turn AC to Auto cool set at 55.**

Go back up and look at softstart light should be green ( there can be a 3 min delay before light come on)

Green Light, shut Ac off replace all covers then turn AC on and allow to run at least 30 min