

Turn ALL Power and Breakers OFF Before Starting Install

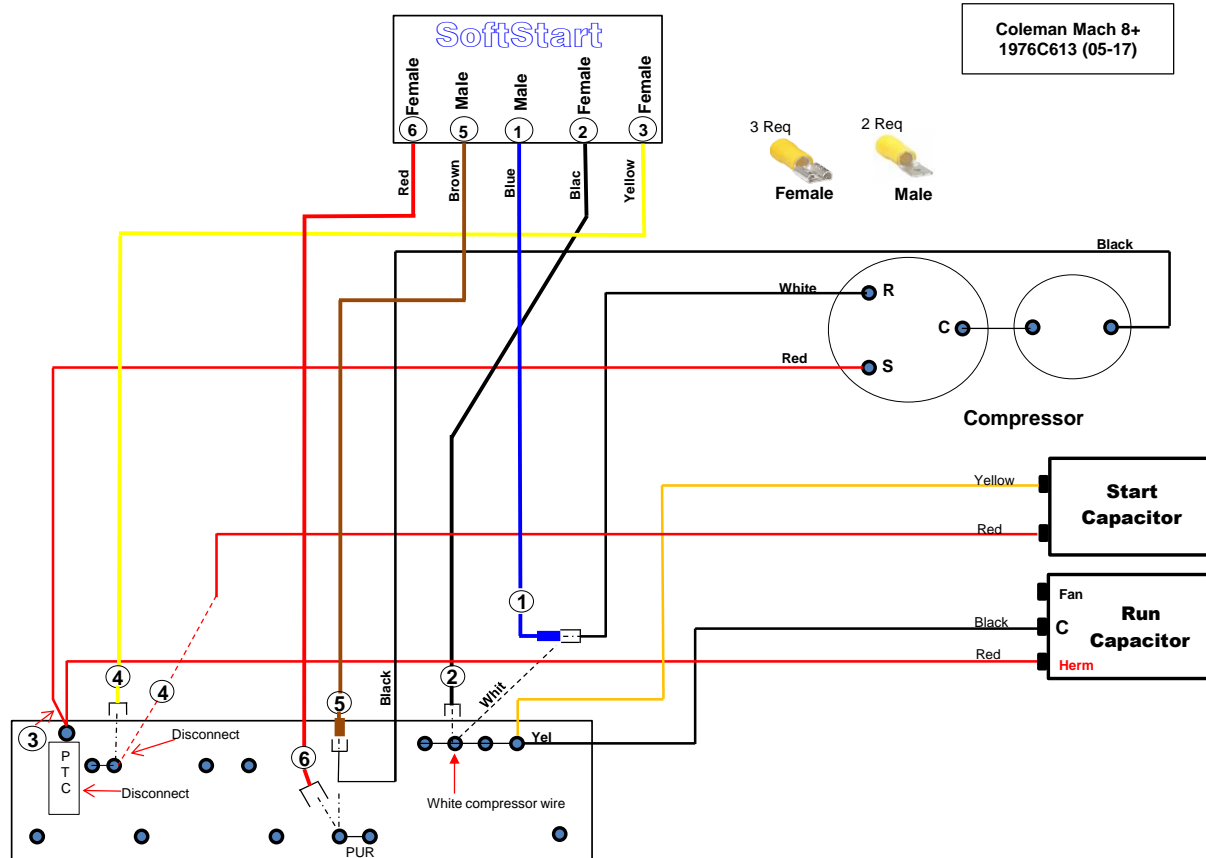

To begin Route ALL softstart wires into electrical box

Crimp disconnect connectors on softstart wires as indicated. (Note: To insure proper connections scrap inside of female and both sides of male connectors)

- Step 1)** Follow white compressor wire to the Yel terminal, Disconnect and connect to Blue Softstart wire
- Step 2)** Connect Black Softstart wire to terminal white compressor wire was on
- Step 3)** **Disconnect the PTCR** and remove the double red wires and connect double red wires to terminal ptc was on
- Step 4)** **Disconnect the single red wire that was next to PTCR**, Connect Yellow softstart wire were single red wire was.
- Step 5)** Disconnect Black Compressor wire from Terminal board (PUR), connect to Brown Softstart wire.
- Step 6)** Connect Red Softstart wire to terminal Black compressor wire was on  
Secure wires to prevent fan pulling them in

Turn Power & Breaker on, Fan on Hi 1 min, Then turn A/C to auto cool, set at 55

**(NOTE:** There may be a 3 min delay before Compressor starts this is normal when Softstart goes into test mode BEFORE the softstart green light comes on)

When you have a Green light you have seccessfully installed your Softstart. Turn ac off secure all wires and replace covers. Turn A/C back on and run for 30 min minimum