

Turn ALL Power and Breakers OFF BEFORE starting install

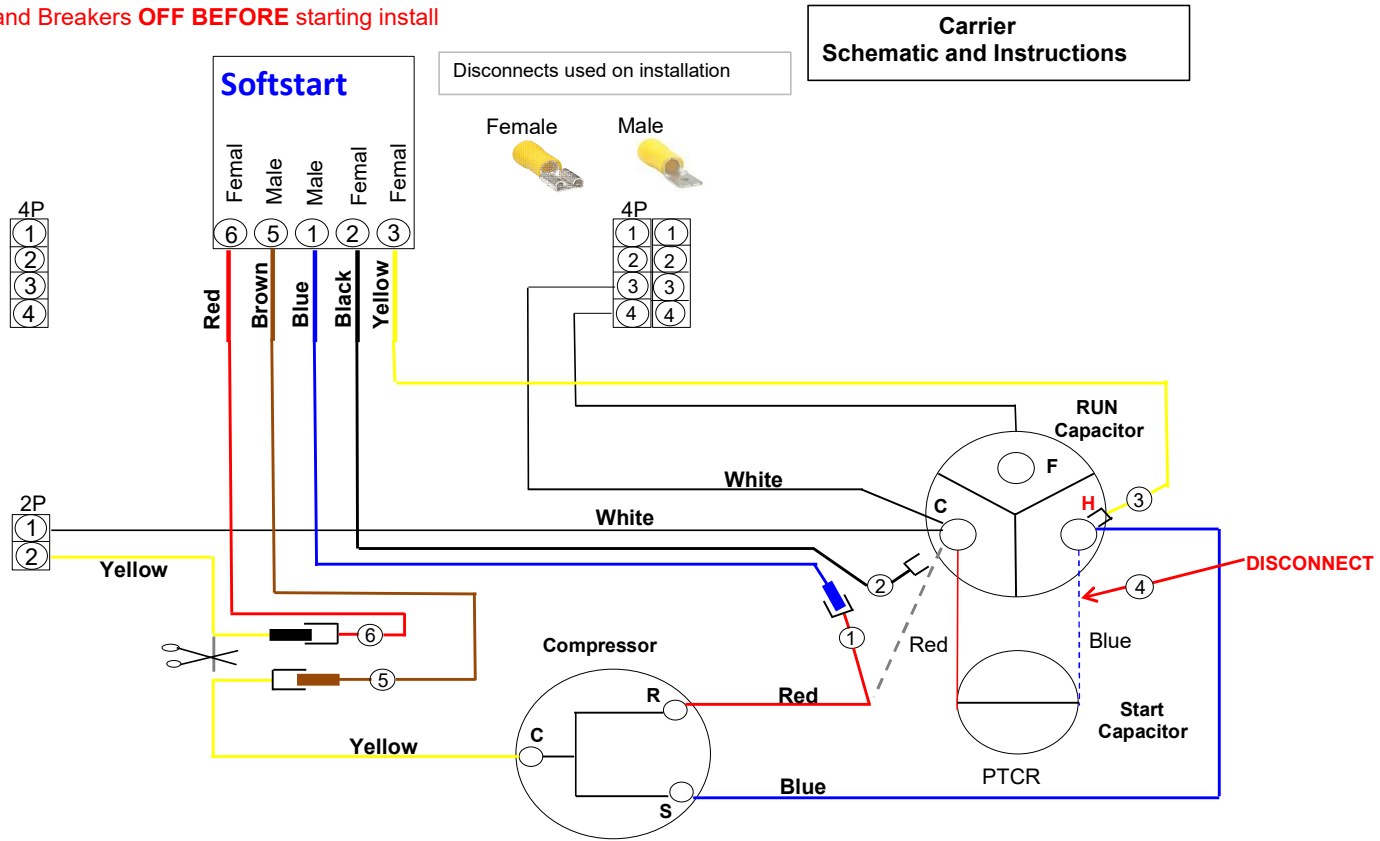

Begin by routing ALL Softstart wire into elctrical box, Then crimp disconnects on wires as shown in Softstart box above

Step 1) Follow Red Compressor wire to "C" Run Capacitor, Disconnect and Connect to Blue Softstart wire

Step 2) Connect Black Softstart wire on terminal Red compressor wire was on.

Step 3) Connect Yellow Softstart wire on terminal next to Blue Compressor wire on "H" Herm Terminal of Run Capacitor

Step 4) Disconnect Blue Start Capacitor wire next to Blue Compressor wire on "H" terminals

Step 5) Cut the yellow compressor wire approx 4" from terminal block, Crimp a female disconnect on yellow end attached to compressor and connect to Brown softstart wire

Step 6) Crimp a male disconnect on the yellow wire to goes toward the terminal block and connect to Red Softstart wire

Secure all wires to prevent fan form pulling wires into it.

Turn Power and Ac breaker on, Turn Fan on Hi 1 min, Turn Ac to auto cool set tstat at 55

Go look a softstart for Green light on left, (There may be a full 3 min delay before the light turns Green)

Green light on turn ac off replace covers, then turn ac back on and allow to run for 30 min.

IF after 3 full min no Green light shut ac down and call tech support