

Turn All Power and Breakers **OFF BEFORE** Starting Install

Attwood AC with Circuit Board

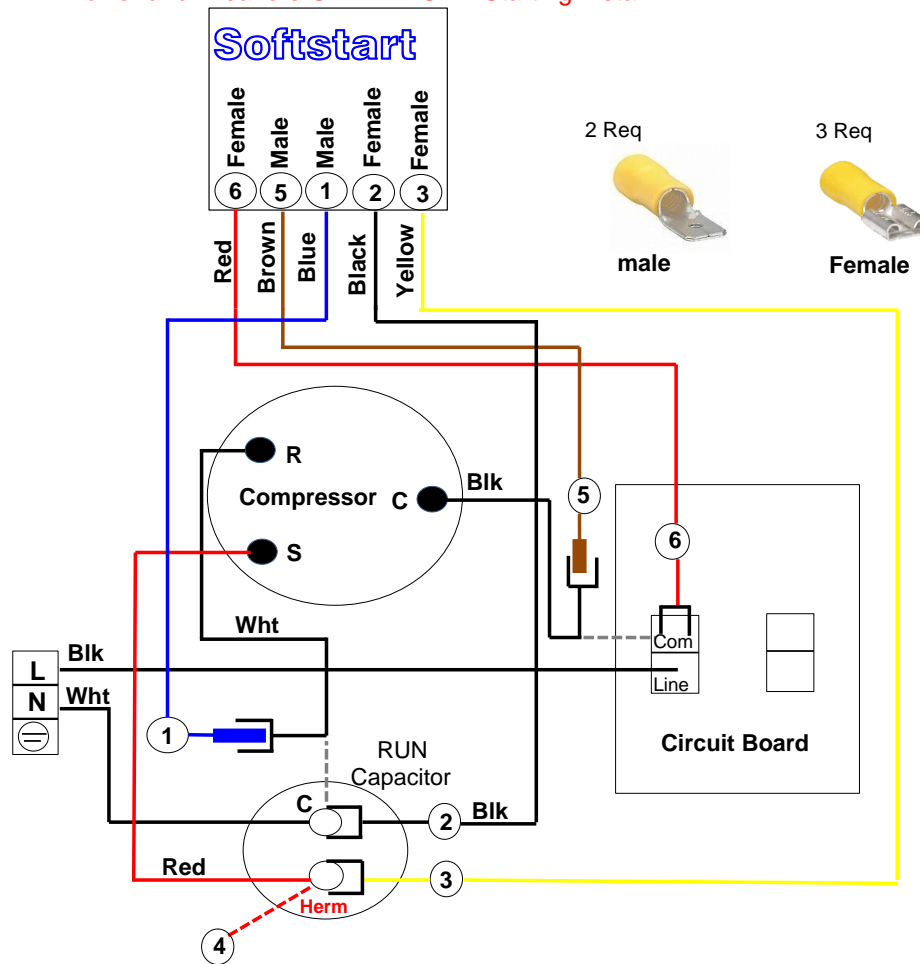

Route All Softstart wires into Electrical Box

Step 1) Follow White Compressor wire to "C" terminal on Run Capacitor, Disconnect and Connect to Blue Softstart wire

Step 2) Connect Black Softstart wire to terminal White compressor wire was on

Step 3) Connect Yellow Softstart wire on terminal next to Red Compressor wire on **Herm** Terminals

Step 4) **IF** you see 2nd Red wire **Disconnect** and tape end

Step 5) Follow black Compressor wire to Circuit Board **COM Port terminal**, Disconnect and connect to Brown Softstart wire

Step 6) Connect Red Softstart wire on **COM port terminal** were Black compressor wire was

Secure wires to prevent fan pulling lose wires in

Turn Power and Ac breaker on, Turn Fan on hi 1 min, Turn AC to Auto Cool and set Tstat to 55

Look at Softstart, light on left should be green (There may be a full 3 min delay before light turns green)

If after 4 min no green light review wirng connections and repeat process. If no green light call Tech support

GREEN LIGHT, shut ac down, replace all covers then turn AC back on and run for 30 min